

Systemair Box Fans

KVD, KVB, KPD & KPB



Systemair Group



Systemair (Spain)



Systemair (Sweden)

Systemair HVAC Spain SLU is a subsidiary in Spain of the Swedish Group Systemair, Europe's leader in ventilation and air conditioning market.

The company currently has all the necessary resources, both personal and material, to respond quickly and effectively to any customer or market demand in the ventilation or air conditioning field.

To provide a more specific and clear idea about our service capacity, just indicate that among other resources we could include:

- A manufacturing plant in Fuenlabrada, Madrid
- 60 employees
- 6700 m² Factory / Warehouse
- 1000 m² Office / other spaces
- 16700 m² plot plot
- Quality System Certification ISO 9001 by BVQI
- S.A.T. highly qualified.

To the above mentioned resources, we should add the fact of belonging to the Systemair Group, which involves, among other advantages:

- 2 central warehouses (Sweden and Germany) and 10 factories in 9 countries covering an area of 130,000 m².
- Production plants located in Sweden including the main plant Skinnskatteberg. The other production plants are located in Denmark, Norway, Germany, Lithuania, Slovenia, Slovakia, Spain, Canada, India and Malaysia.
- Financial strength. The Group Systemair, created in 1974, currently consists of more than 2,500 employees and over 350 million € per year, growing at an average rate of 16% per year.
- Having an R & D and testing laboratory, certified by AMCA, and considered the most modern in the ventilation industry in Europe.

Thanks to the resources listed above, together with the continuous effort of our staff to improve everyday the service to our customers and the quality of our products, Systemair HVAC Spain SLU, has become a highly reliable partner for most companies of the ventilation and air conditioning market.

Contents

KVD - KVB	4
KPD - KPB	5
Technical Data	6
Dimensions	8
Accessories	10
Selection Curves	11
KP DUO	17
Specification Text	19



KVD – KVB

Casing in galvanized steel with standard roof and feet* for outdoor installation*

KVD (direct driven) and KVB (belt driven) from sizes 5/8 to 30/28* are a range of single skin supply or extract box fans for inline application. These fans are designed for cost effective installations with low to medium pressure drop whilst keeping very good sound performances.

- KVD – Double inlet Direct Driven range with airflows from 550 to 7500 m³/h, IP 54 Class Motors single phase.
- KVB – Double inlet belt driven range with airflows from 700 to 50 000 m³/h IP 55 Class F motors (IE2 Motors).

Features & benefits

- Robust and quiet operation thanks to the galvanized steel fan and motor support mounted on 4 anti-vibration rubber plots.
- Outlet connected to the casing through an 18 mm thick rubber joint acting as a flexible seal.
- Reinforced bottom panel giving the box fan more stability and mechanical resistance.
- Indoor and outdoor installation with the same standard unit.
- Easy to install with motor wired to the IP 55 connection box. KVB and KVD have a round inlet and square outlet.
- Efficient double inlet galvanized steel forward curved impeller balanced statically and dynamically. Operates with air up to 50°C.
- Please note again that from sizes 20/20 to 30/28 the construction is the same than KPB but without isolation.



* From 20/20 to 30/28 with Aluminium Profile without isolation (see page 5).

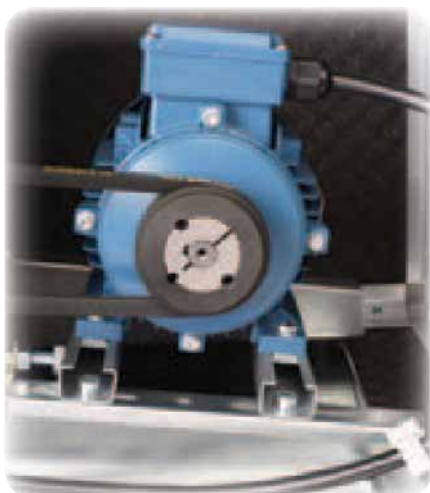

*Casing with aluminium profile 15 mm
polyurethane foam isolation*

KPD – KPB

KPD (direct driven) and KPB (belt driven) from size 7/7 to 30/28 are a range of supply or extract box fan for inline. The casing is made of an aluminum frame with single skin or double skin galvanized steel panels or PVC. These fans are designed for indoor and outdoor installations with low to medium pressure drop whilst keeping very good sound performances.

- KPB – Double inlet belt driven range with airflows from 700 to 50 000 m³/h IP 55 F Class IEC motors (IE2 Motors) (380 V 50 and 60 Hz).
- Suitable for operating temperatures of up to 50°C.

Features & benefits

- Robust and quiet operation thanks to the galvanized steel fan and motor support mounted on 4 anti-vibration rubber plots.
- Low noise level: Anti-vibration rubber adjustable feet are fitted below the fan casing.
- Outlet connected to the casing through an 18 mm thick rubber joint acting as a flexible seal, the size 20/20 to 30/28 have a flexible canvas.
- Quality casing with aluminum profile structure, plastic corners, M1 fire rated 15 mm isolation through polyurethane foam.
- Easy access: A maintenance access door on the side is fitted with polyamide hinges and ¼ turn lock and key.
- Easy to install with motor wired to the IP 55 connection box.
- Efficient double inlet galvanized steel forward curved impeller balanced statically and dynamically.
- Inlet panel of KPB is to be ordered with rectangular inlet, damper or closed. The outlet is square.
- From the sizes 20/20 to 30/28 have baseframe instead of feet.



Technical data Direct driven

KVD - KPD Direct driven

Size	Watts	Max m ³ /h	A (max m ³ /h)	V/Hz	r.p.m max	IP	Wiring diagram	Lpa 1m	Weight (kg)
5-8-E4 (36 W)	36	500	0,8	230/50	1200	54	1	52	12
7-7-E4 (146 W)	146	1700	1.5	230/50	1410	54	1	58	20
7-7-E6 (73 W)	73	1685	0.96	230/50	960	54	1	54	20
9-7-E4 (370 W)	370	2750	3.22	230/50	1410	54	1	61	30
9-7-E6 (237 W)	237	2510	2.4	230/50	950	54	1	59	30
9-9-E4 (370 W)	370	2800	3.22	230/50	1400	54	1	61	30
9-9-E4 (550 W)	550	3150	4.3	230/50	1450	54	1	64	32
9-9-E6 (237 W)	237	2590	2.4	230/50	950	54	1	61	31
10-8-E6 (237 W)	237	2550	2.4	230/50	950	54	1	63	35
10-10-E4 (550 W)	550	3250	4.3	230/50	1375	54	1	66	37
10-10-E6 (237 W)	237	2700	2.4	230/50	950	54	1	63	36
10-10-E6 (525 W)	525	4825	4.3	230/50	950	54	1	65	42
12-9-E6 (765 W)	765	4820	6.5	230/50	950	54	1	62	50
12-12-E6 (525 W)	525	4400	4.3	230/50	950	54	1	64	50
12-12-E6 (765 W)	765	5750	6.5	230/50	910	54	1	67	52
12-12-E6 (1100 W)	1100	7150	7.8	230/50	910	54	1	71	53.5

Electrical wiring

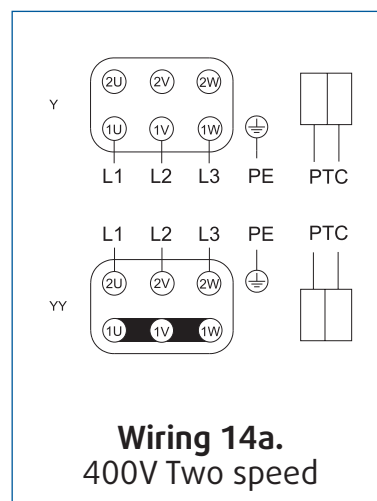
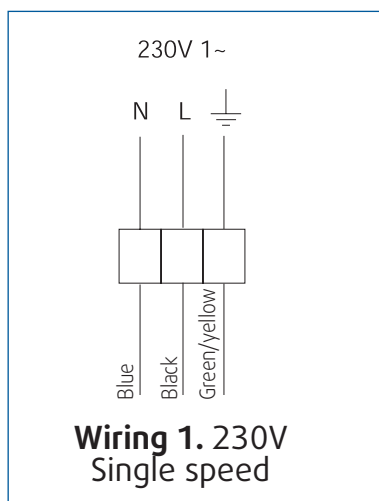

Technical data Belt driven

KVB - KPB Belt driven

	Motor kW Min - Max	Max m ³ /h	V	Hz	Motor r.p.m	Wiring 1 speed	Wiring 2 speed	Weight (kg) Min - Max
7/7	0.25 - 0.55	2800	400	50/60	1450	13a	14a	32 - 37
9/7	0.25 - 1.1	4100	400	50/60	1450	13a	14a	44 - 52
9/9	0.25 - 1.1	4500	400	50/60	1450	13a	14a	45 - 53
10/8	0.37 - 1.5	5100	400	50/60	1450	13a	14a	50 - 59
10/10	0.37 - 1.5	6200	400	50/60	1450	13a	14a	54 - 60
12/9	0.55 - 2.2	6800	400	50/60	1450	13a	14a	71 - 87
12/12	0.55 - 2.2	9000	400	50/60	1450	13a	14a	73 - 89
15/11	0.55 - 3	9500	400	50/60	1450	13a	14a	98 - 122
15/15	0.55 - 3	12800	400	50/60	1450	13a	14a	112 - 136
18/13	0.75 - 7.5	15500	400	50/60	1450	13a	14a	130 - 180
18/18	0.75 - 7.5	19500	400	50/60	1450	13a	14a	139 - 189
20/20	1,5 - 7.5	25000	400	50/60	1450	13a	14a	250 - 300
22/22	2,2 - 11	30000	400	50/60	1450	13a	14a	300 - 373
25/25	2,2 - 15	40000	400	50/60	1450	13a	14a	350 - 435
30/28	3 - 15	50000	400	50/60	1450	13a	14a	450 - 535

IEC Motor IP 55 F Class

kW	Amp
0.25	0.8
0.37	1.1
0.55	1.5
0.75	1.9
1.1	2.6
1.5	3.5
2.2	4.9
3	6.7
4	8.4
5.5	11.3
7.5	14.8
11	22
15	29

Wiring diagram

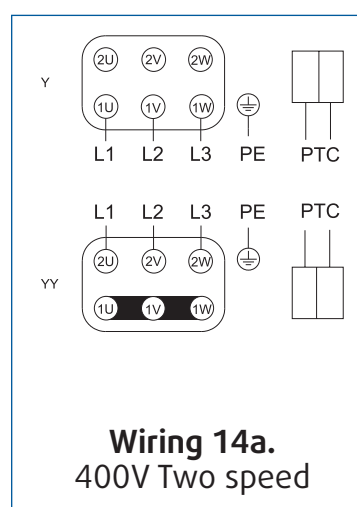
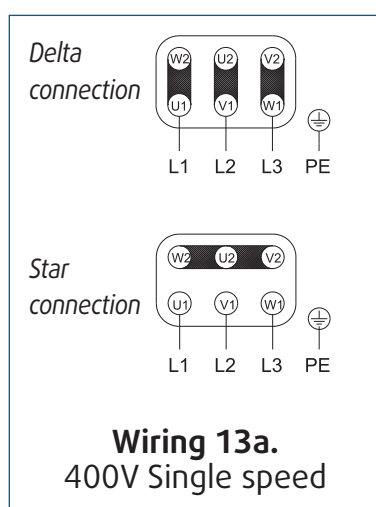

Dimensions KVD & KVB

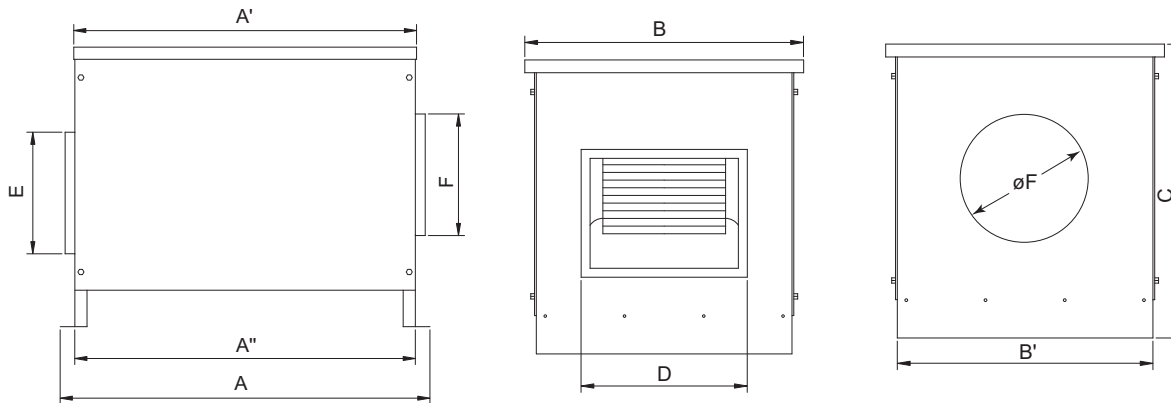

KVD Direct driven single skin

	A	A'	A''	B	B'	C	D	E	øF
5-8	390	348	344	502	462	324	288	129	200
7-7	498	458	454	457	415	442	273	253	200
9-7	548	508	504	507	465	532	336	304	250
9-9	548	508	504	507	465	532	336	304	250
10-8	648	608	604	607	565	592	371	330	300
10-10	648	608	604	607	565	592	371	330	300
12-9	698	658	654	657	615	642	434	382	350
12-12	698	658	654	657	615	642	434	382	350

KVB Belt driven single skin

	A	A'	A''	B	B'	C	D	E	øF
7-7	598	558	555	457	412	441	273	253	250
9-7	748	708	705	562	512	541	336	304	300
9-9	748	708	705	562	512	541	336	304	300
10-8	798	758	755	657	612	591	371	330	350
10-10	798	758	755	657	612	591	371	330	350
12-9	948	908	905	812	762	691	434	382	400
12-12	948	908	905	812	762	691	434	382	400
15-11	1045	1005	1002	962	912	791	508	445	500
15-15	1045	1005	1002	962	912	791	508	445	500
18-13	1195	1155	1152	1150	1100	981	594	518	600
18-18	1195	1155	1152	1150	1100	981	594	518	600

All dimensions in mm

Dimensions KPD & KPB

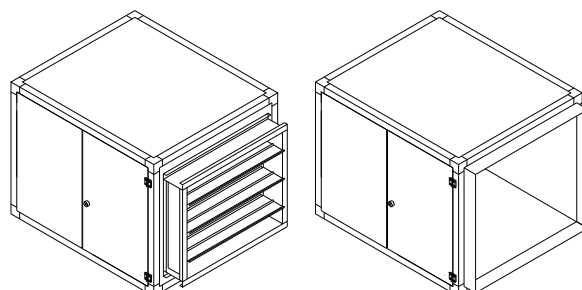
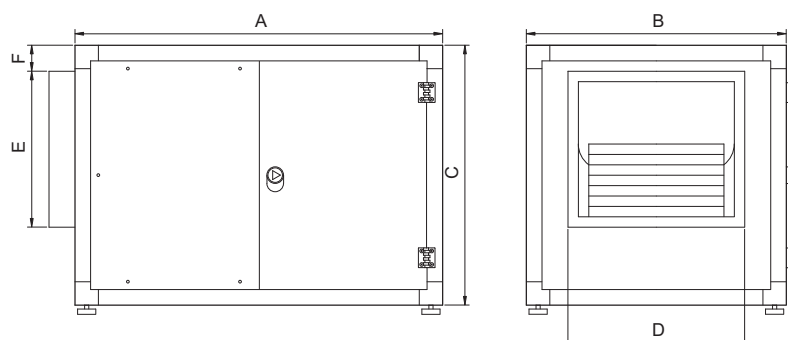

KPB Belt driven

	A	B	C	D	E	F
7-7	600	450	450	272	251	68
9-7	700	550	550	336	304	94
9-9	700	550	550	336	304	94
10-8	750	650	600	371	330	85
10-10	750	650	600	371	330	85
12-9	900	800	700	434	383	112
12-12	900	800	700	434	383	112
15-11	1000	950	800	508	443	128
15-15	1000	950	800	508	443	128
18-13	1150	1100	1000	594	518	120
18-18	1150	1100	1000	594	518	120

Inlet options

Manual damper		Rectangular inlet	
L Length	H Height	L Length	H Height
300	288	390	390
400	416	490	490
400	416	490	490
500	416	590	540
500	416	590	540
650	544	740	640
650	544	740	640
800	672	890	740
800	672	890	740
900	800	1000	900
900	800	1000	900

KPD Direct driven single skin

	A	B	C	D	E	F
7-7	450	450	450	210	251	66
9-7	500	500	500	336	304	66
9-9	500	500	500	336	304	66
10-8	550	550	550	371	330	72
10-10	550	550	550	371	330	72
12-9	630	630	630	434	383	75
12-12	630	630	630	434	383	75

Inlet options

Manual damper		Rectangular inlet	
L Length	H Height	L Length	H Height
300	288	390	390
350	288	440	440
350	288	440	440
400	416	490	490
400	416	490	490
450	416	570	570
450	416	570	570

All dimensions in mm

Dimensions KPD & KPB

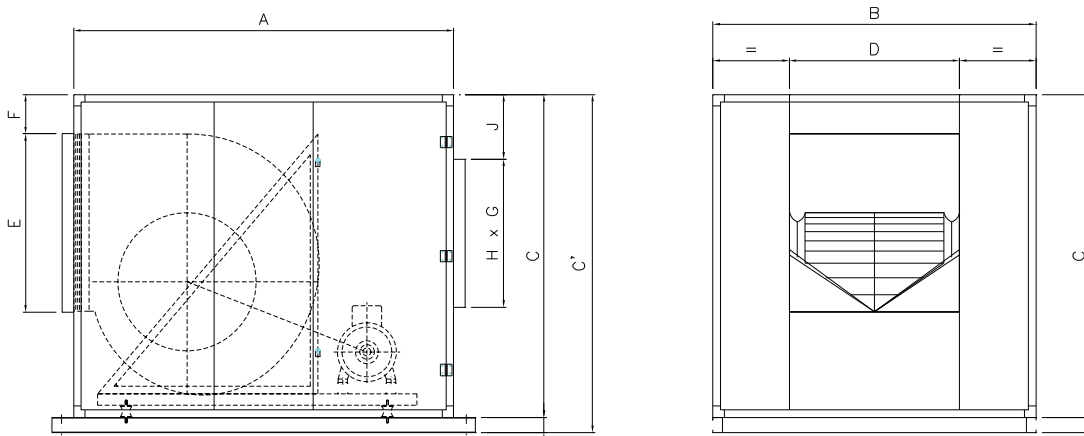

KVB & KPB Belt driven (same construction)

	A	A'	B	C	C'	D	E	F	G	H	J
20-20	1550	1780	1350	1250	1330	610	610	193	1270	900	175
22-22	1650	1880	1350	1250	1330	661	701	112	1270	900	175
25-25	1700	1930	1450	1450	1530	771	800	186	1370	830	40
30-28	2000	2230	1700	1700	1780	896	939	206	1620	780	340

Inlet options	
Manual damper	
L Length	H Height
1000	1056
1000	1056
1200	1184
1400	1312

All dimensions in mm

Accessories Range

	KVD	KVB	KPD	KPB
Outlet	✓	✓	✓	✓
Inlet	✗	✗	✓	✓
Terminal Box	✓	✗	✗	✗
Power Switch	✓	✓	✓	✓
Pressure Switch	✓	✓	✓	✓
Filter	✗	✗	✓	✓
Roof	✗	✗	✓	✓
Double Skin	✗	✗	✓	✓
PVC	✗	✗	✓	✓
Damper	✗	✗	✓	✓
Inlet with Intake	✗	✗	✓	✓

Selection curves KVB & KPB (Belt driven)

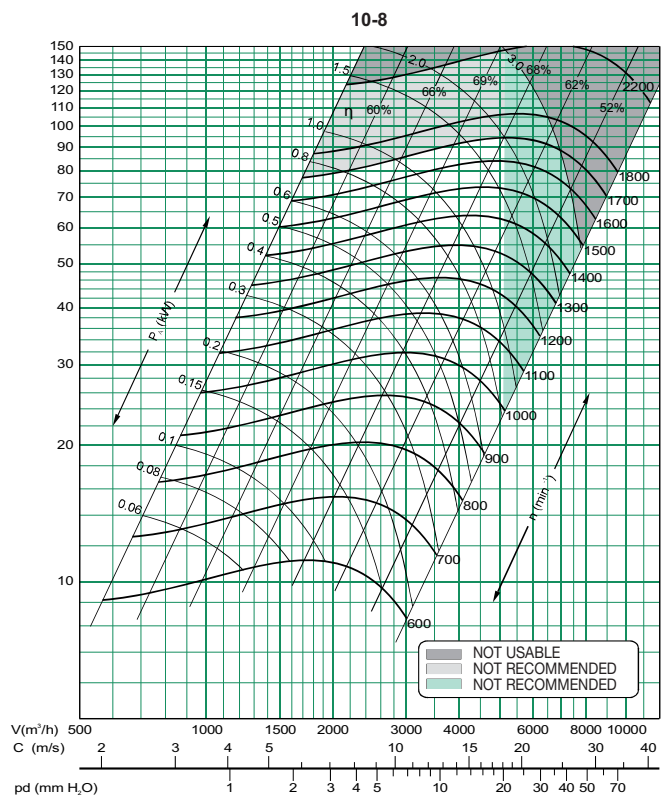
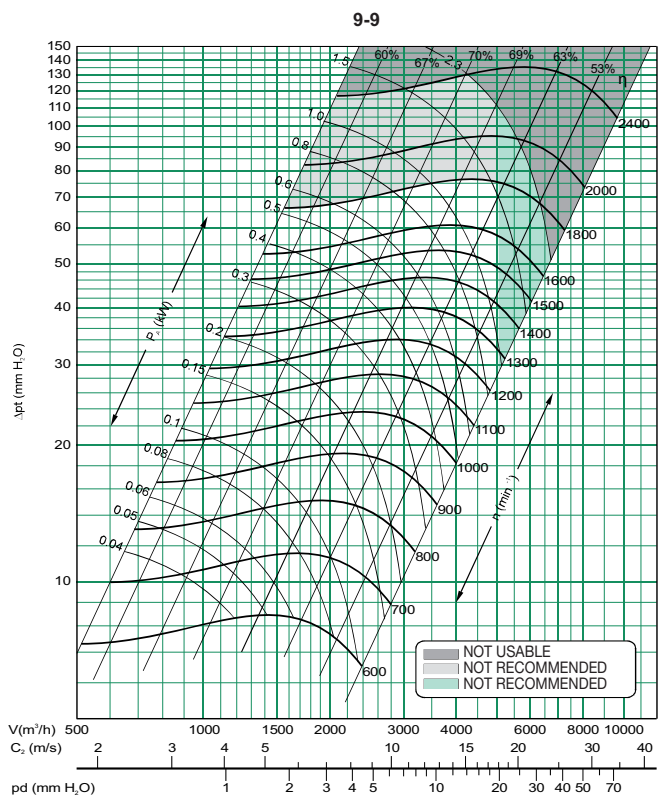
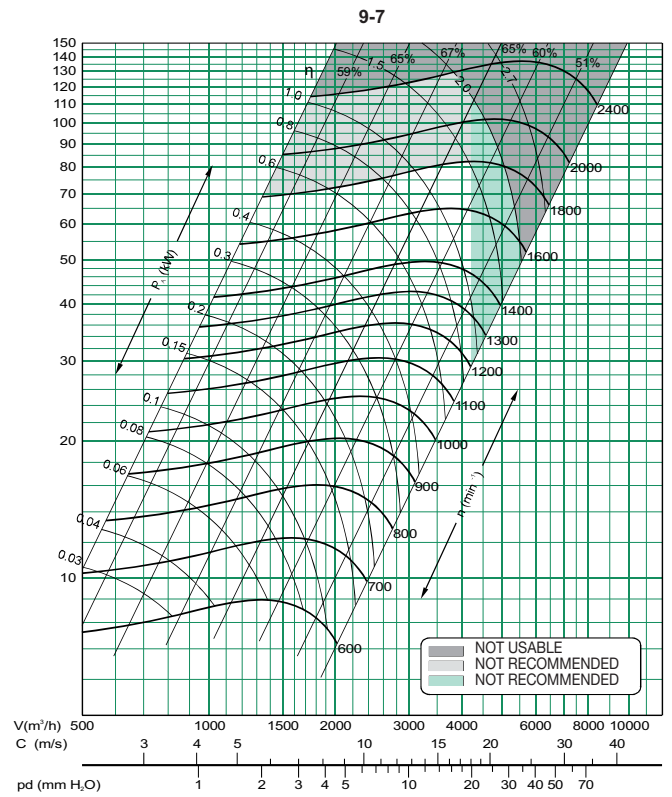
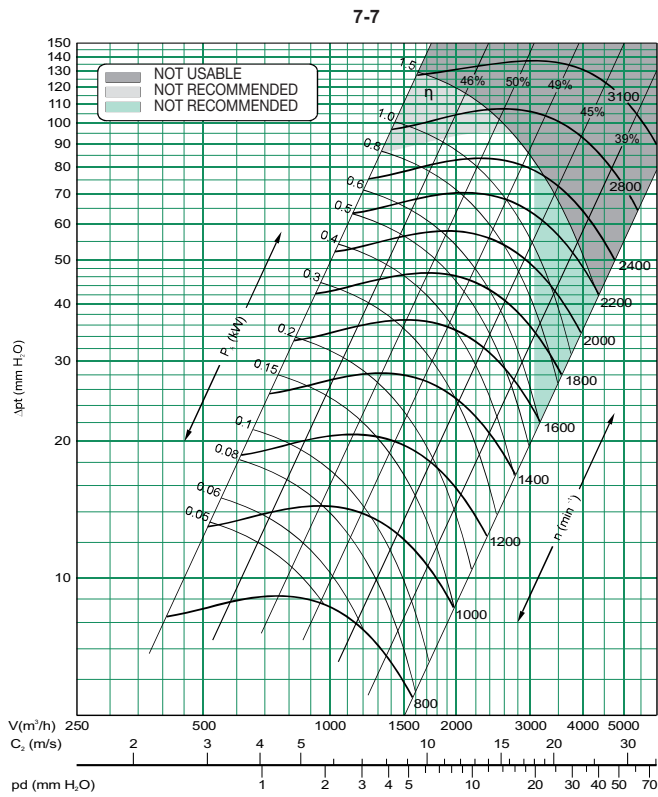

Selection curves KVB & KPB (Belt driven)

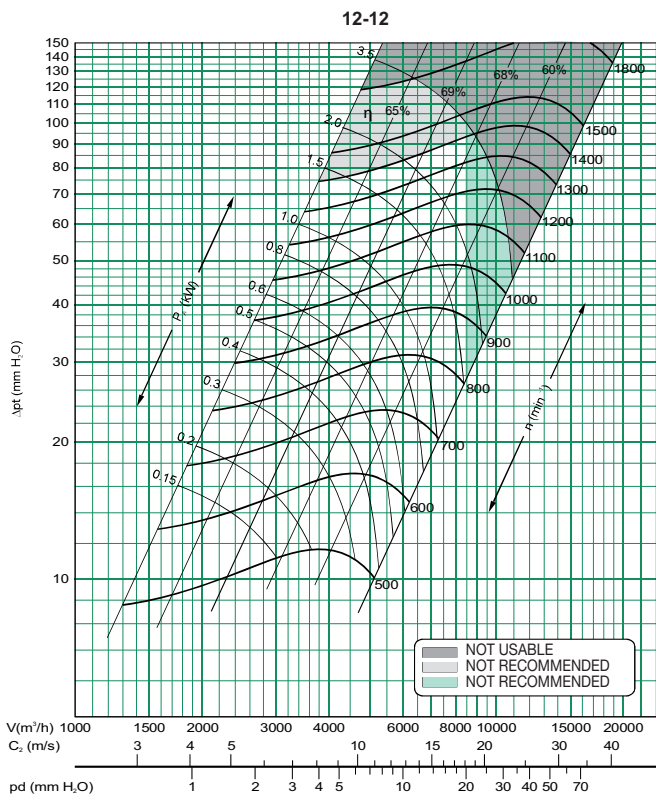
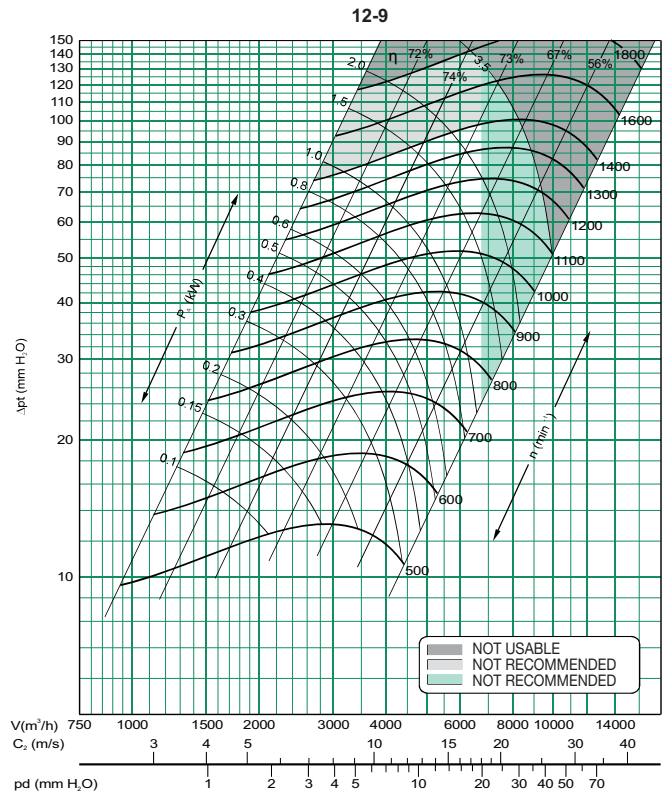
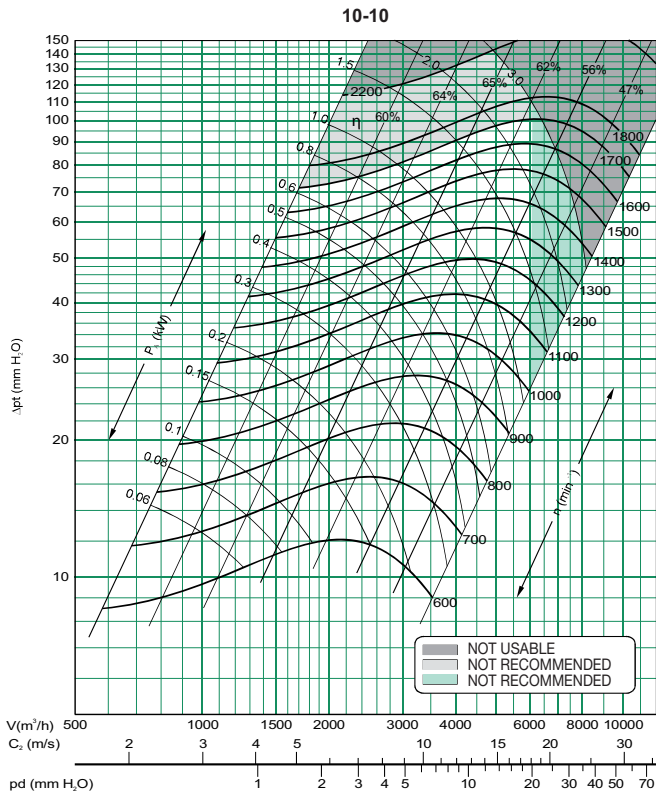

Selection curves KVB & KPB (Belt driven)

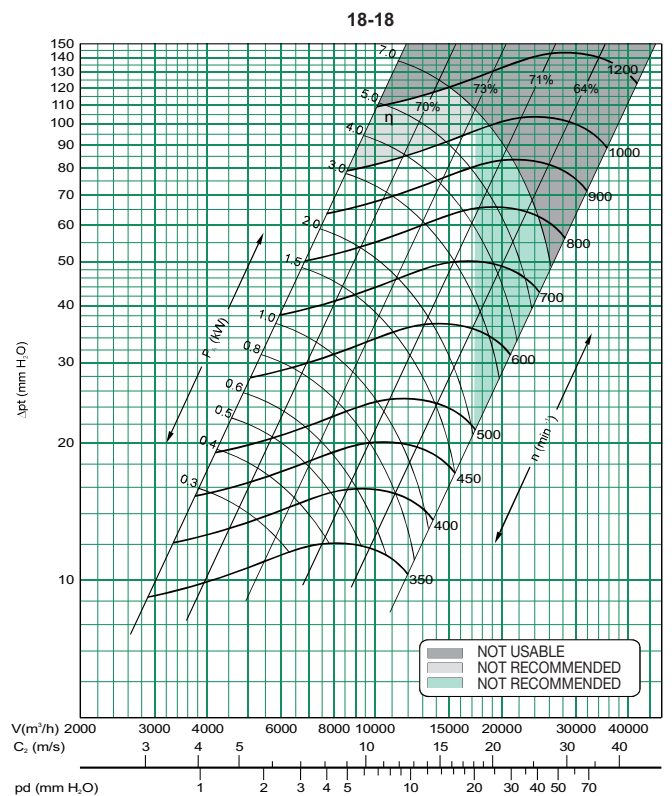
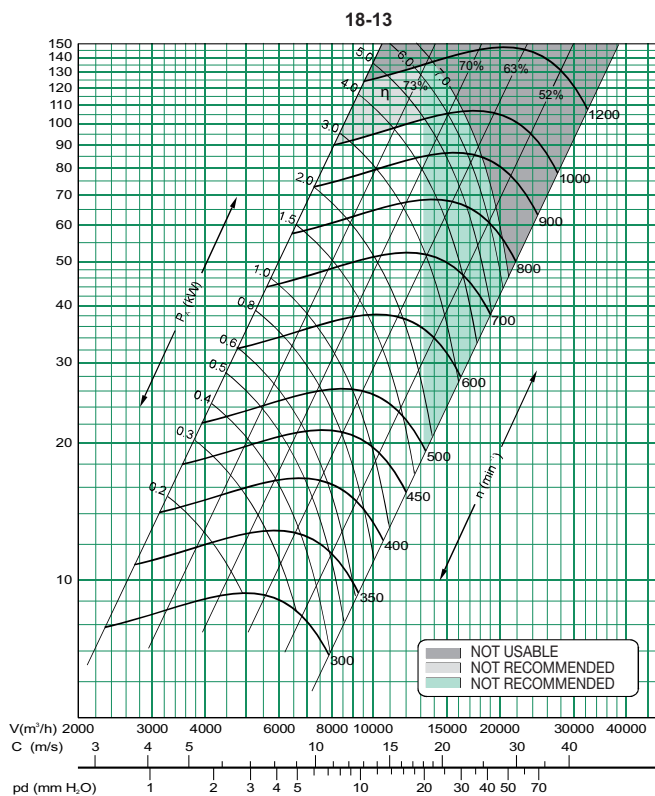
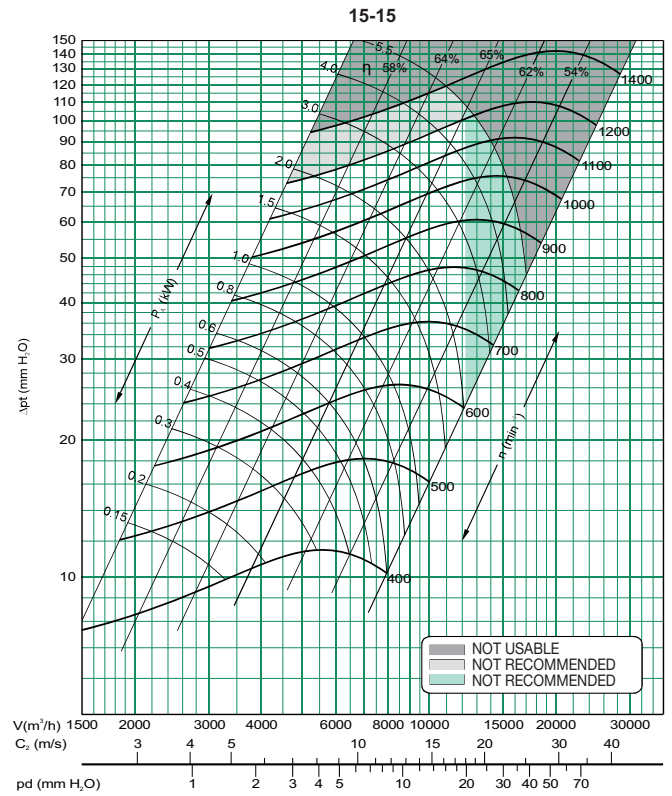
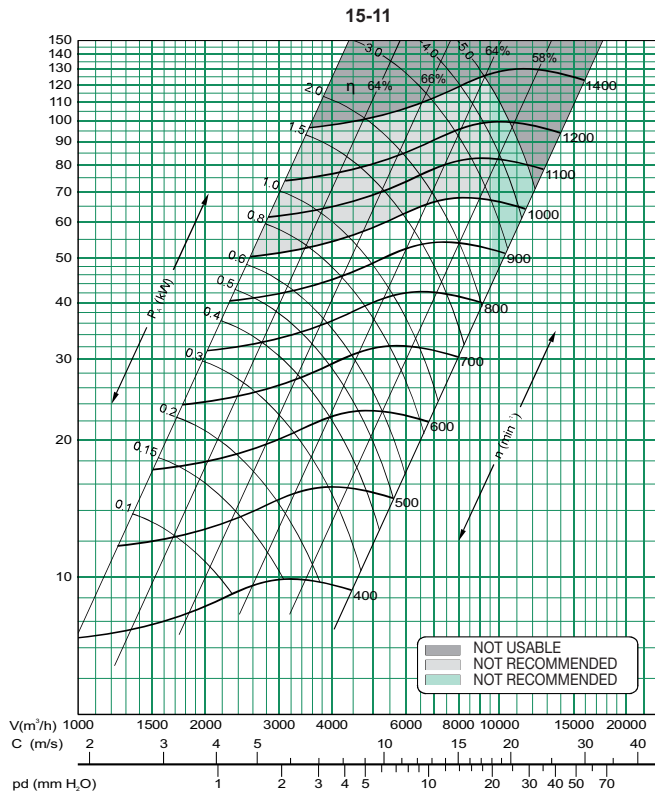

Selection curves KVB & KPB (Belt driven)

20-20

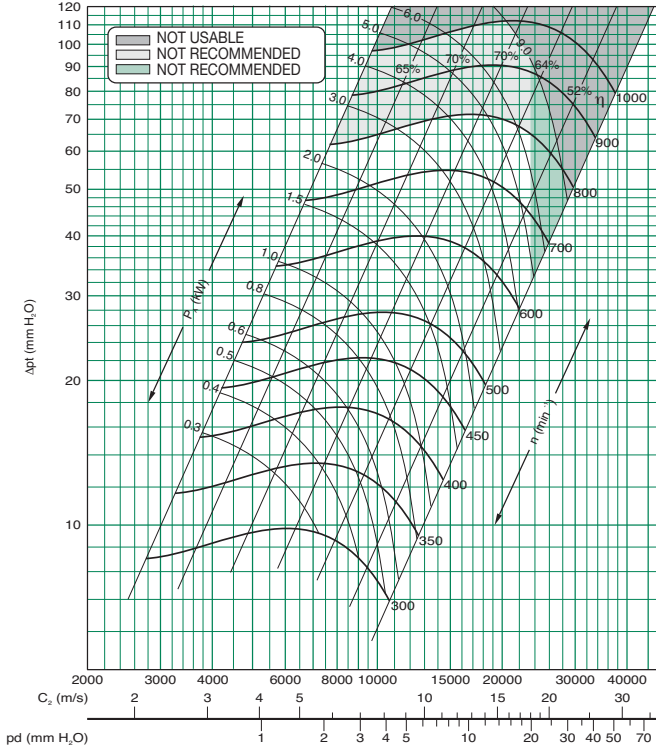

22-22

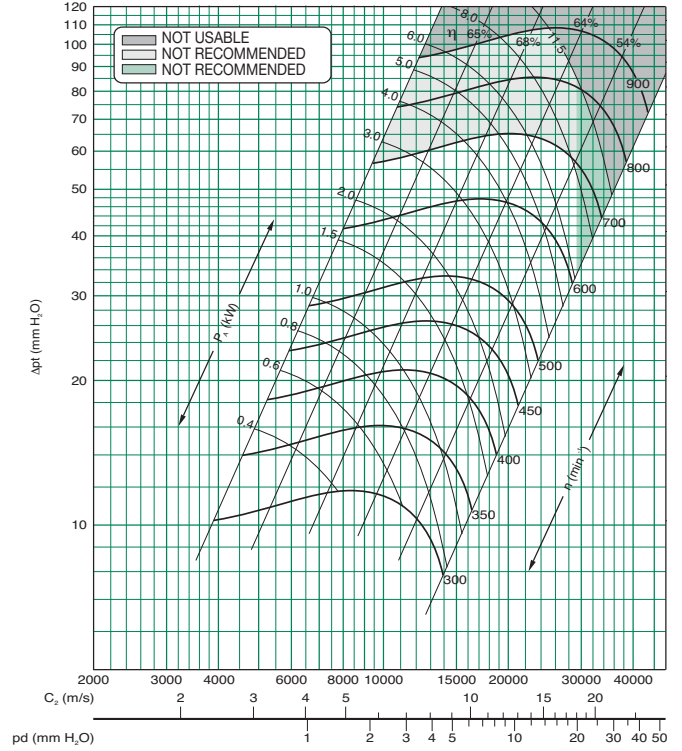

25-25

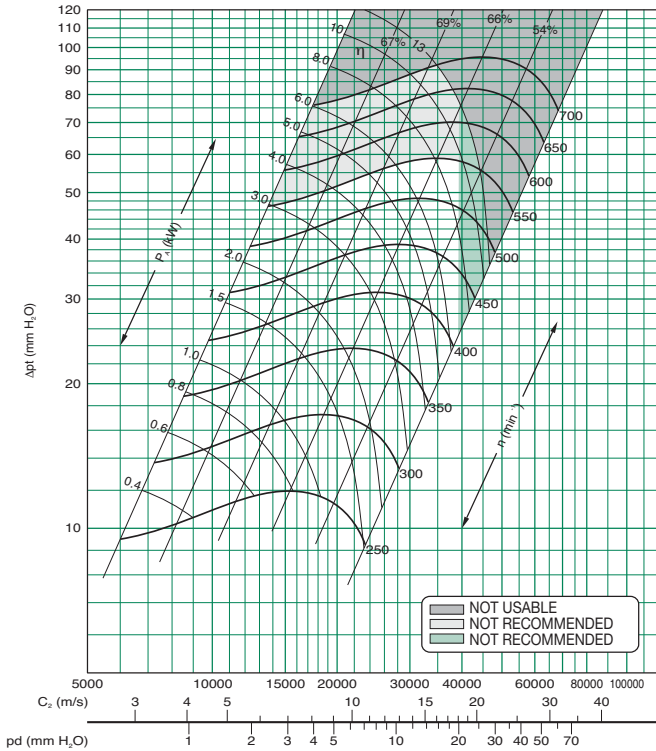

30-28

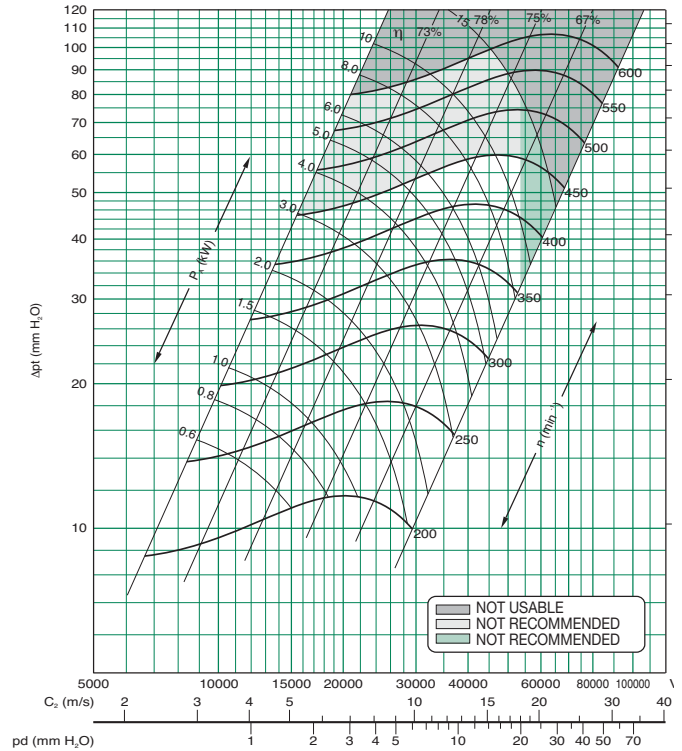

Selection curves KVD & KPD

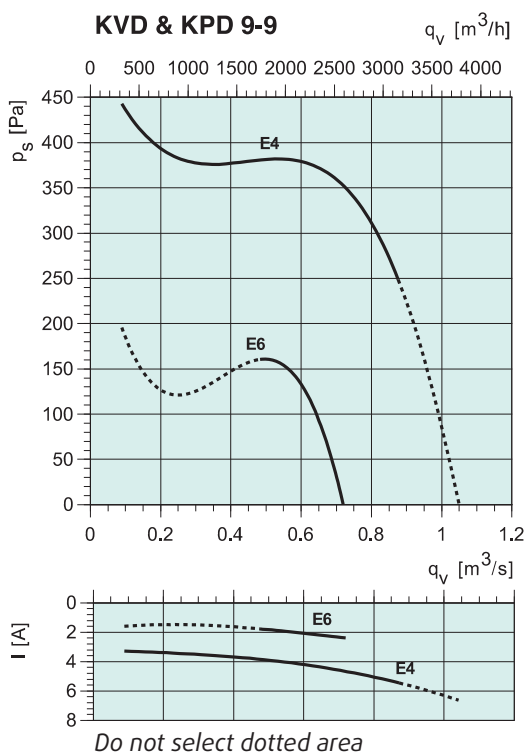
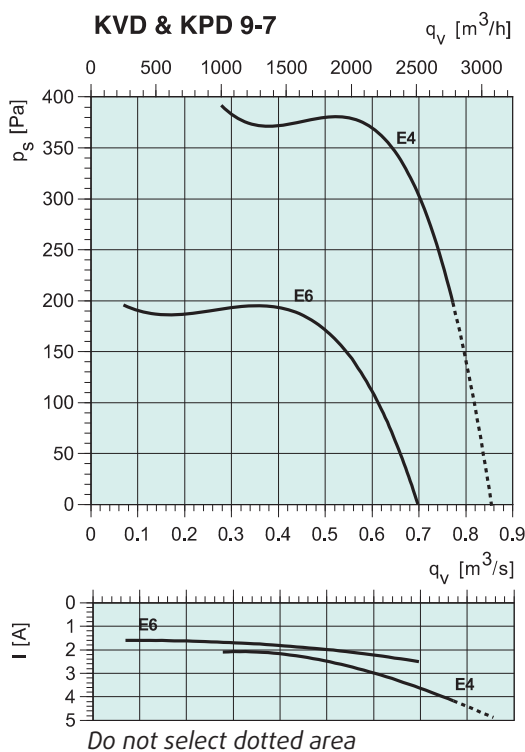
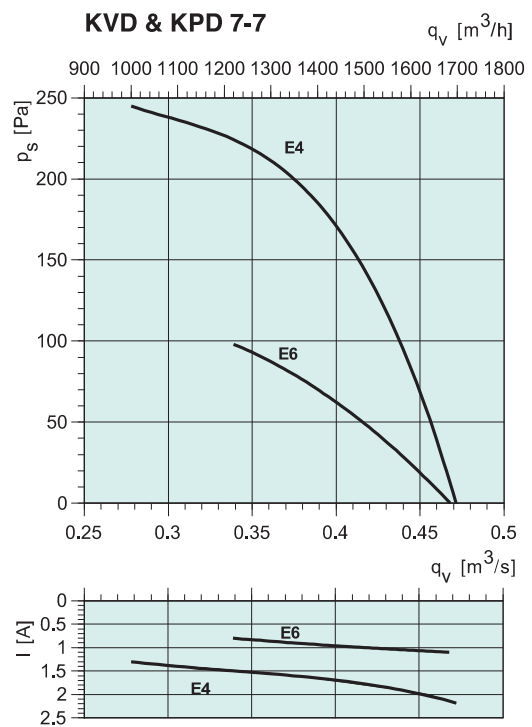
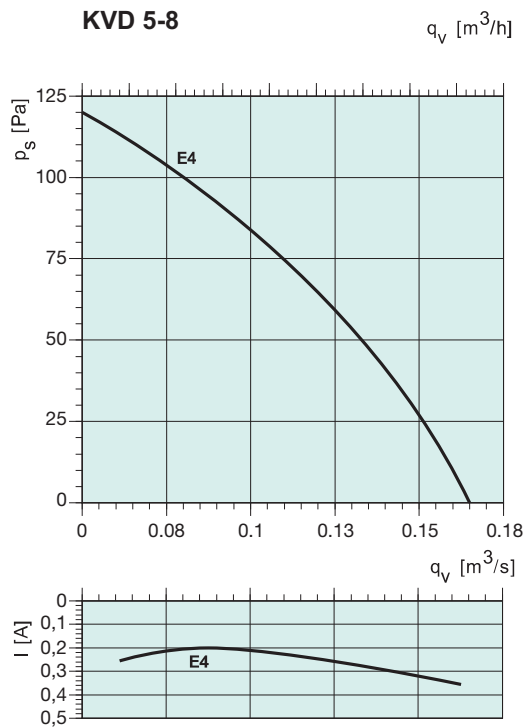

Selection curves KVD & KPD

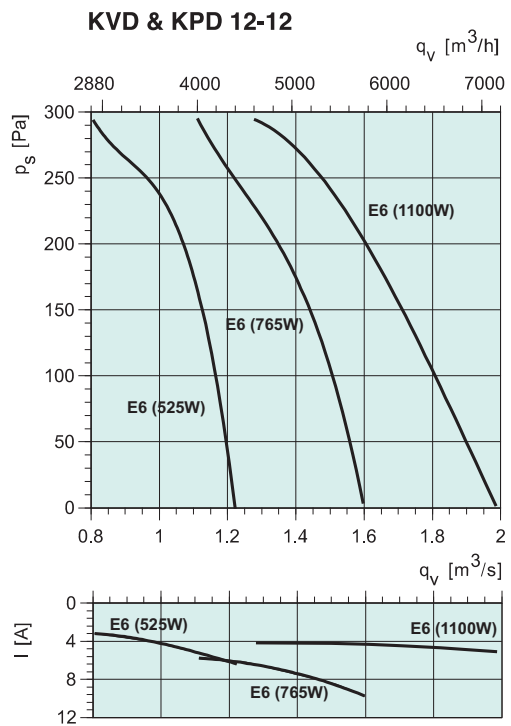
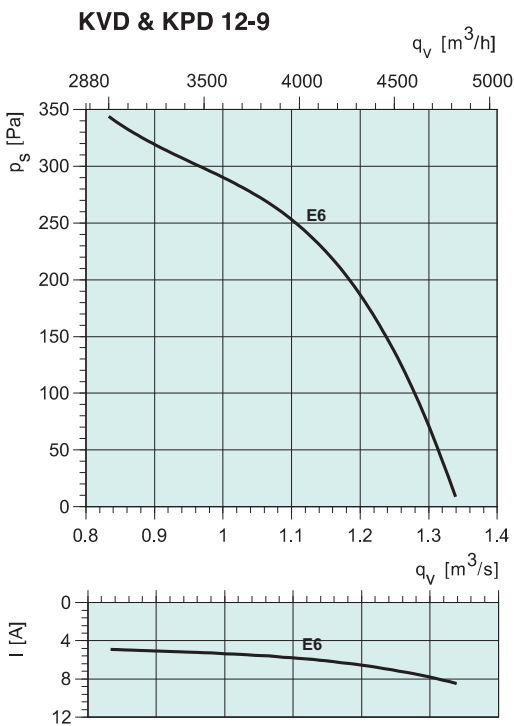
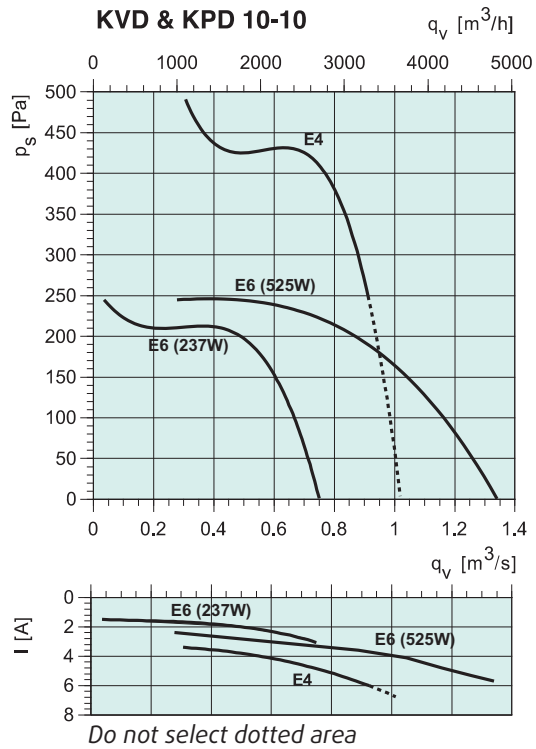
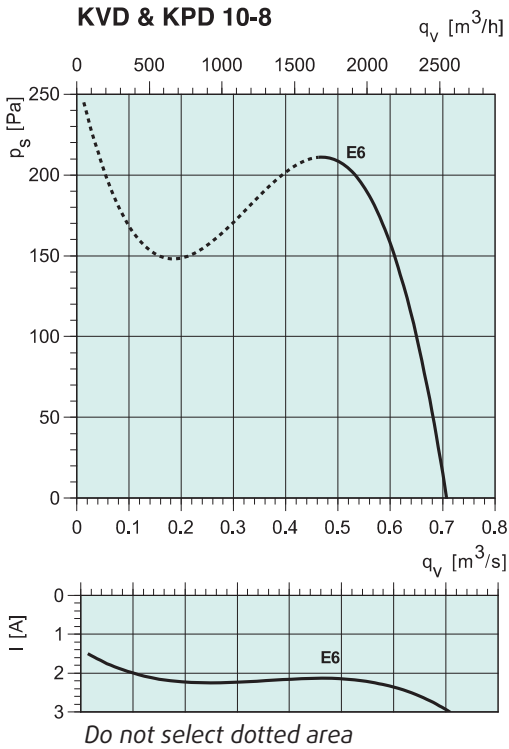

KP DUO

The KP DUO is a range of acoustically treated in-line centrifugal twin fans for internal and external mounting with aluminum profile casing. The direct driven KPD DUO ranges from 700 to 7000 m³/h while the standard range belt driven KPB DUO reaches 17 000 m³/h. Static pressures up to 700 Pa. A rectangular inlet and outlet allows an easy connection to ducts avoiding sudden pressure loss. 9 sizes are available from 450 to 1000 mm height. Suitable for operations up to 50°C.

Features & Benefits

Quiet operation

- Aluminum profile heavy duty casing with 15 mm isolation on galvanized steel panels
- Fan and motor supported on a metallic frame with built in vibration isolation

Quality impellers and motors

- Highly efficient forward curved double inlet galvanized steel impeller.
- IP 55 F Class motors, belt driven (three phase) IE2. Direct drive IP 54 F Class single phase except 12-12-D6.

Easy installation & maintenance

- IP 55 wired connection box for easy wiring of the two motors.
- Maintenance access door with lock and key.



Dimensions KPB DUO

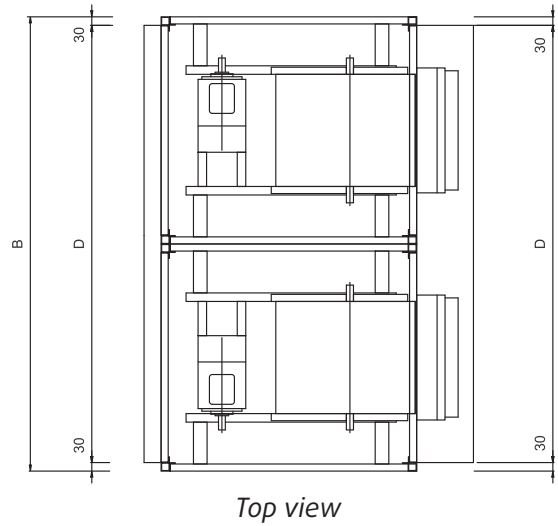
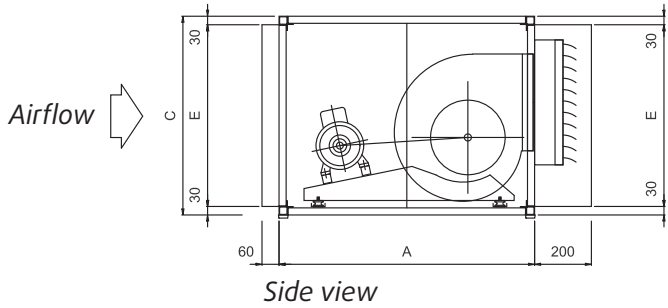

KPB DUO Belt driven

	A	B	C	D	E
7/7	600	900	450	840	390
9/7	700	1100	550	1040	490
9/9	700	1100	550	1040	490
10/8	750	1300	600	1240	540
10/10	750	1300	600	1240	540
12/9	900	1600	700	1540	640
12/12	900	1600	700	1540	640
15/11	1000	1900	800	1840	740
15/15	1000	1900	800	1840	740
18/13	1150	2200	1000	2140	940
18/18	1150	2200	1000	2140	940

KPD DUO Direct driven

	A	B	C	D	E
7/7	450	900	450	840	390
9/7	500	1000	500	940	440
9/9	500	1000	500	940	440
10/8	550	1100	550	1040	490
10/10	550	1100	550	1040	490
12/9	630	1260	630	1200	570
12/12	630	1260	630	1200	570

Specification text

KVD

Direct driven box fan for inline operation and suitable for outdoor installations fitted with a forward curve double inlet impeller and IP 54 F Class motors. The casing is made of 1 mm thick galvanized steel. The impeller shall be fitted on 4 anti-vibration rubber plots and its outlet connected with the casing through a 18 mm thick rubber joint. An IP 55 connection box is fitted on the casing for easy installation.

Maximum temperature of the transported air: 50°C

KVB

Belt driven box fan for inline operation and suitable for outdoor installations fitted with a forward curve double inlet impeller and IP 55 F Class motors. The casing is made of 1 mm thick galvanized steel. The impeller and motor shall be fitted on a galvanized steel support with 4 anti-vibration rubber plots, the impeller's outlet connected with the casing through a 18 mm thick rubber joint. An IP 55 connection box is fitted on the casing for easy installation.

Maximum temperature of the transported air: 50°C

KPB

Belt driven box fan for inline or 90° operation suitable for outdoor installation fitted with a forward curve double inlet impeller and IP 55 F Class motors. The casing is made of aluminum profile structure and 1 mm galvanized steel panels fitted with 15 mm M1 polyurethane foam insulation. A maintenance door with polyamide hinge and key is located on the side of the box. The impeller and motor shall be fitted on a galvanized steel support with 4 anti-vibration rubber plots and the impeller's outlet connected with the casing through a 18 mm thick rubber joint.

Maximum temperature of the transported air: 50°C

KPD

Direct driven twin fan for inline operation suitable for outdoor installation fitted with a forward curve double inlet impeller and IP 55 F Class motors. The casing is made of aluminum profile structure and 1 mm galvanized steel panels fitted with 15 mm M1 polyurethane foam insulation. A maintenance door with polyamide hinge and key is located on the side of the box. The impeller shall be fitted on a galvanized steel support with 4 anti-vibration rubber plots and its outlet connected with the casing through a 18 mm thick rubber joint.

Maximum temperature of the transported air: 50°C.

KPB Duo

Belt driven twin fan for inline operation suitable for outdoor installation fitted with a forward curve double inlet impeller and IP 55 F Class motors. The casing is made of aluminum profile structure and 1 mm galvanized steel panels fitted with 15 mm M1 polyurethane foam insulation. A maintenance door with polyamide hinge and key is located on the side of the box. The impeller and motor shall be fitted on a galvanized steel support with 4 anti-vibration rubber plots and the impeller's outlet connected with the casing through a 18 mm thick rubber joint.

Maximum temperature of the transported air: 50°C. An IP 55 connection box for both motors is fitted on the casing.

KPD Duo

Direct driven twin fan for inline operation suitable for outdoor installation fitted with a forward curve double inlet impeller and IP 55 F Class motors. The casing is made of aluminum profile structure and 1 mm galvanized steel panels fitted with 15 mm M1 polyurethane foam insulation. A maintenance door with polyamide hinge and key is located on the side of the box. The impeller shall be fitted on a galvanized steel support with 4 anti-vibration rubber plots and its outlet connected with the casing through a 18 mm thick rubber joint.

Maximum temperature of the transported air: 50°C. An IP 55 connection box for both motors is fitted on the casing.

The characteristics of the equipment described in this catalogue (e.g., sizes, features, etc.) may be modified without prior notice.

The catalogues published by SYSTEMAIR are reviewed and amended whenever necessary and any such modifications are made in new editions. The catalogue edition is printed on the inside back cover and the user is responsible for using the latest edition.

Please visit our website at <http://www.systemair.es>



Systemair HVAC Spain S.L.U.

C/Montecarlo, 14

28942 Fuenlabrada (Madrid)

Spain

Teléfono: +34 91 600 29 00

Fax: +34 91 600 29 08

www.systemair.es